

Research of composite nanosized oxides $(\text{TiO}_2)_x(\text{SiO}_2)_{1-x}$ and Si-C- O_x synthesized using a non-equilibrium plasmochemical process

A. I. Pushkarev, G. E. Remnev, D. V. Ponomarev

High Voltages Research Institute Russia, 634050, Tomsk, pr. Lenin 2a, e-mail: aipush@mail.ru

The results of investigations into the properties of composite nanosized powders of $(\text{TiO}_2)_x(\text{SiO}_2)_{1-x}$ and Si-C- O_x are given. The powders are synthesized using a non-equilibrium plasmochemical process initiated by a pulsed electron beam. The initial gas mixture consists of oxygen, hydrogen, and a mixture of halides ($\text{TiCl}_4 + \text{SiCl}_4$ or $\text{SiCl}_4 + \text{CCl}_4$) with the total pressure 400 – 700 Torr. The average grain size of the synthesized powder is 29 nm for $(\text{TiO}_2)_x(\text{SiO}_2)_{1-x}$ and 47 nm for Si-C- O_x . The paper presents the results of TEM examination, X-ray diffraction and X-ray fluorescence analyses, and IR spectrometry. It is found out that the composite nanosized $(\text{TiO}_2)_x(\text{SiO}_2)_{1-x}$ powder has crystal structure while Si-C- O_x is amorphous. It is demonstrated that the process of the synthesis is volumetric. The energy consumed by the electrophysical setup to synthesize the powder is 0.1–0.15 (kW·h)/kg and the output rate is 1–1.1 kg/h calculated per final reaction product. It is shown that it is the non-equilibrium character of the process that makes it possible to lower the temperature threshold for the crystal structure to develop in the product particles.

Introduction

Titanium dioxide is one of the most important commercial inorganic materials. It is used as a white pigment, photocatalyst, semiconductor in voltaic cells, etc. The world consumption of TiO_2 in 2001 exceeded 4 million ton. Along with the nanosized titanium and silicon dioxides, there is a great scientific interest in the study of a composite containing both of these dioxides. Many of the useful properties exhibited by TiO_2 , such as its catalytic activity, high reflectivity, etc., could be considerably improved by a change in the structure of titanium dioxide in the presence of amorphous silicon dioxide. In addition, the use of a cheap carrier for titanium dioxide offers a possibility to considerably reduce the cost of the synthesized material while maintaining its useful properties. The composite material $(\text{TiO}_2)_x(\text{SiO}_2)_{1-x}$ is a challenge from the point of view of metallographic investigation of a change in the structure of crystalline titanium dioxide when amorphous silicon dioxide is embedded into its matrix.

The use of non-equilibrium plasmochemical processes is of great promise for the synthesis of nanosized oxides. It is their non-equilibrium character that provides a possibility to considerably reduce the energy consumption for the reaction and change its conditions. A non-equilibrium process initiated by a pulsed electron beam was used to synthesize nanosized silicon dioxide [1, 2] and titanium dioxide [3, 4]. The energy of the electrophysical installation consumed to convert silicon tetrachloride (SiCl_4) was as low as 0.02 eV/molecule. The aim of this work is to study nanosized $(\text{TiO}_2)_x(\text{SiO}_2)_{1-x}$ and Si-C- O_x powders synthesized in a non-equilibrium plasmochemical process under a pulsed e-beam.

1. An overview of the techniques to synthesize nanosized $(\text{TiO}_2)_x(\text{SiO}_2)_{1-x}$

For the synthesis of a composite $(\text{TiO}_2)_x(\text{SiO}_2)_{1-x}$ material, use is largely made of the sol-gel method. The resulting amorphous material is further subjected to thermal treatment at the temperature above 500 °C to remove the hydroxyl group and the precursor material left.

In [5], amorphous $(\text{TiO}_2)_x(\text{SiO}_2)_{1-x}$ ($x = 0.08, 0.18$ and 0.41) was investigated using X-ray phase analysis, neutron diffraction, infra-red spectrometry, thermal gravimetry, and other analytical techniques. As precursor materials use was made of tetraethylorthosilicate (TEOS) and titanium tetraisopropoxide ($\text{C}_4\text{H}_9\text{O}_4\text{Ti}$). It was found out that at a comparatively low concentration ($x = 0.08$) titanium is embedded into the lattice of titanium dioxide to form the Ti-O-Si bond. This concentration of titanium is below its limit of solubility in silicon dioxide. Given a high concentration ($x = 0.41$), the phases of titanium dioxide and silicon dioxide are separated already in the initial gel, and the general structure of the resulting material is amorphous. When the composite $(\text{TiO}_2)_x(\text{SiO}_2)_{1-x}$ ($x = 0.41$)

material is heated to the temperature above 500 °C, titanium dioxide forms a crystal lattice with the structure of anatase. It was noted in [5] that the presence of amorphous silicon dioxide retards rearrangement of the crystal structure of titanium dioxide of the anatase type into that of the rutile type. No rutile-type lattice was found out when the composite material ($x = 0.41$) was heated to 800 °C. Initially, the composite material $(\text{TiO}_2)_x(\text{SiO}_2)_{1-x}$ with the average concentration of titanium ($x = 0.18$) was characterized by a Ti-O-Ti bonding. Upon heating the gel to 500 °C, all the titanium atoms formed a Ti-O-Si structure. When the gel was further heated (750 °C and higher), this structure was decomposed to form separate phases of silicon dioxide and titanium dioxide (anatase).

In [6] the results of investigation of the composite $(\text{TiO}_2)_x(\text{SiO}_2)_{1-x}$ ($x = 0.1, 0.3$ and 0.5) are presented, which was formed by the sol-gel synthesis tetraethylorthosilicate and titanium tetraisopropoxide. The initial gel was a composite of TiO_2 and SiO_2 with a conspicuous number of Si-O-Ti structures. As the temperature was increased, there was an increase in the number of Si-O-Ti bonds that decomposed at higher temperatures. The structure of the composite after thermal treatment was a matrix made up by pure silicon dioxide with particles of crystalline titanium dioxide having either an anatase or rutile lattice, depending on the treatment temperature. A concurrent research in [6] was made into the changes in the structure of titanium dioxide synthesized by the same method from titanium tetraisopropoxide. Initially in the course of heating to 420 °C, the amorphous gel TiO_2 acquired crystal structure with the anatase-type lattice. When heated to above 800 °C, it exhibited a rearrangement of its crystal lattice into the rutile form. The composite material rearranged from the amorphous structure into crystalline (anatase) at the temperature above 600° and maintained the anatase lattice in heating to 1000 °C.

The results of investigation into the formation of nanosized composite material from a mixture of titanium dioxide (anatase) gel and silicon dioxide gel with different mixture ratios are given in [7]. The mixture of these gels was dried in air at 110 °C and was further annealed at 800 °C for 1 hour. The structure of pure TiO_2 during the high-temperature annealing treatment was partially rearranged into the rutile-type lattice. An addition of silicon dioxide inhibited the rearrangement of the crystal lattice of the former during pyrolysis. The authors conclude that an annealing treatment for 1 hour at 800 °C did not form any solid solution of Ti-O-Si, and the initial oxides were present in the composite material as separate phases.

A study of the physical characteristics of silicon dioxide aerogel with 5 % titanium dioxide was made in [8]. The composite material was synthesized from nanosized SiO_2 gel in ethanol with an addition of nanosized TiO_2 (anatase). The emulsion was dried in air and subjected to thermal treatment. An IR-spectrometry analysis did not reveal any formation of the Ti-O-Si bonding either in the initial composite material or after annealing up to 1000 °C, the initial oxides did not form any solid solution. With the use of TEM it was found out that TiO_2 particles are built into the structure of silicon dioxide particles 5 nm in size. As in the previous papers, it was noted that the presence of silicon dioxide inhibits rearrangement of the initial structure of titanium dioxide from anatase to rutile even at 1000 °C.

In [9], the results of investigation of a composite $(\text{TiO}_2)_x(\text{SiO}_2)_{1-x}$ material synthesized by a thermal decomposition of the metalloorganic precursor containing silicon and titanium atoms in one molecule. In that work, three compounds were studied $[\text{Si}(\text{OBut})_2\text{OTi}(\text{acac})_2\text{O}]_2$, $[(\text{ButO})_3\text{SiO}]_2\text{Ti}(\text{OPri})_2$ and $[(\text{ButO})_3\text{SiO}]_3\text{Ti}(\text{OPri})$, which differed by the number of titanium atoms in the molecule of titansiloxanes. The composite material was formed as a nanostructured film with the grain size from 4 to 200 nm (depending on the pyrolysis temperature). An examination of the adsorption IR-spectra demonstrated that with increase in temperature the intensity of the peak from the Si-O-Ti bond is decreased, while the intensity of the adsorption peaks from the Si-O-Si and Ti-O-Ti bonds is increased. This is indicative of the formation of separate phases of titanium dioxide and silicon dioxide at a high-temperature pyrolysis. At high temperature of decomposition of the initial metalloorganic compound, titanium dioxide formed a crystal anatase-type lattice. It is worth noting that the minimum temperature required for titanium dioxide to crystallize in the composite material under study was 600 – 800 °C for different precursors. With increase in the number of titanium atoms in the precursor molecule, the minimum pyrolysis temperature at which the formation of crystal structure in TiO_2 is decreased. A crystal phase of titanium dioxide of the rutile type was formed in minor quantities at the pyrolysis temperature 1100 °C only.

2. Experimental setup.

The work presents the results of research into nanosized oxide powder synthesized using a non-equilibrium plasmachemical process initiated by a pulsed electron beam. The investigation was performed in a pulsed electron accelerator TEU-500 [10]. The electron beam parameters were as follows: electron energy 500 keV, FWHM 60 ns, energy per pulse 100 J, pulse repetition rate 0.5 Hz and beam diameter 5 cm. The reactor used was a cylinder made of quartz glass with an internal diameter of 14 cm and a volume of 6 liters. Nanosized composite $(\text{TiO}_2)_x(\text{SiO}_2)_{1-x}$ was synthesized by injecting a pulsed electron beam into a gas-phase mixture of titanium tetrachloride, silicon tetrachloride, oxygen and hydrogen. The experimental system is presented in figure 1.

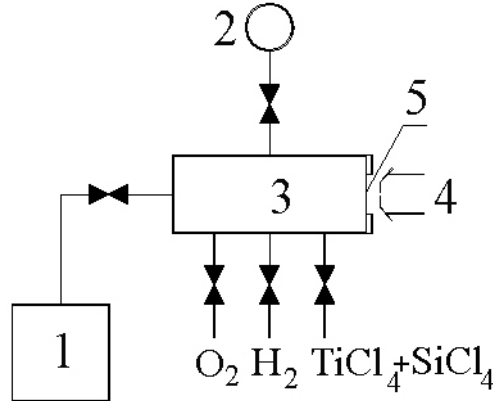

Figure 1. Experimental setup: 1 – vacuum pump; 2 – pressure gauge; 3 – plasmachemical reactor, 4 – electron beam; 5 – anode foil.

Decomposition of mixture of halides ($\text{TiCl}_4 + \text{SiCl}_4$ or $\text{SiCl}_4 + \text{CCl}_4$) was completed within a single electron beam pulse. With the electron beam energy 100 J, the energy consumption for decomposition of mixture of halides was 5 kJ/mol. This is by far smaller than the TiCl_4 dissociation energy that is equal to 804 kJ/mol. The process of destruction of $\text{TiCl}_4 + \text{SiCl}_4$ with hydrogen and oxygen with an electron beam injected into this mixture had an explosive character. This circumstance, the presence of a lower limit (on pressure) of the reactive mixture ignition, and the low energy consumption are indicative of a cross-linked chain character of the process of composite $(\text{TiO}_2)_x(\text{SiO}_2)_{1-x}$ synthesis through decomposition of $\text{TiCl}_4 + \text{SiCl}_4$ in a mixture with oxygen and hydrogen.

The use of a closed plasmachemical reactor and the pulsed process of the synthesis make it possible to calculate the variation of temperature in the course of the synthesis from the variation of pressure in the reactor. Shown in figure 2 is the time dependence of the reactor temperature. The calculation has been made from an experimental dependence for pressure variation using the equation of state for ideal gases.

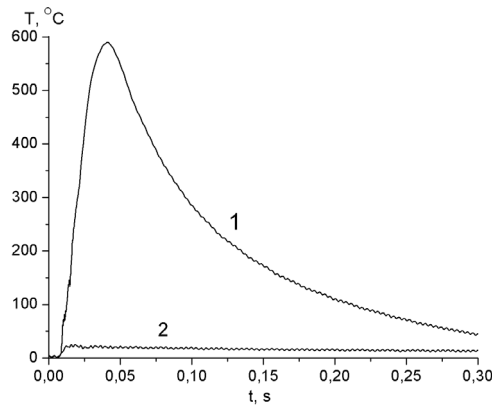

Figure 2. Temperature variation in a plasmachemical reactor in the course of synthesis of nanosized oxides (curve 1) and temperature variation only (without ignition) due to heating of the gas mixture by an electron beam (curve 2).

The measurements made have shown that the gas-phase mixture temperature in the course of synthesis is maintained not higher than 600 °C, and the duration of the process is less than 0.1 s.

3. Plasmochemical synthesis of composite oxides $(\text{TiO}_2)_x(\text{SiO}_2)_{1-x}$.

In order to understand whether it is possible to simultaneously synthesize nanosized oxides of different materials, a number of experiments have been conducted to excite a mixture of oxygen, hydrogen, titanium tetrachloride and tetrachlorsilane by a pulsed electron beam. For the synthesis of composite oxides use was made of technological tetrachlorsilane. The reactor was heated to 90 °C and, before filling in the gas mixture, evacuated to ~1 Pa. Upon injecting the electron beam into the following mixture (mmol): $\text{H}_2 + \text{O}_2 + \text{SiCl}_4 + \text{TiCl}_4$ (50 : 25 : 17 : 10), nanosized powder was formed in the reaction chamber. Figure 3 shows a SEM image of the resulting powder.

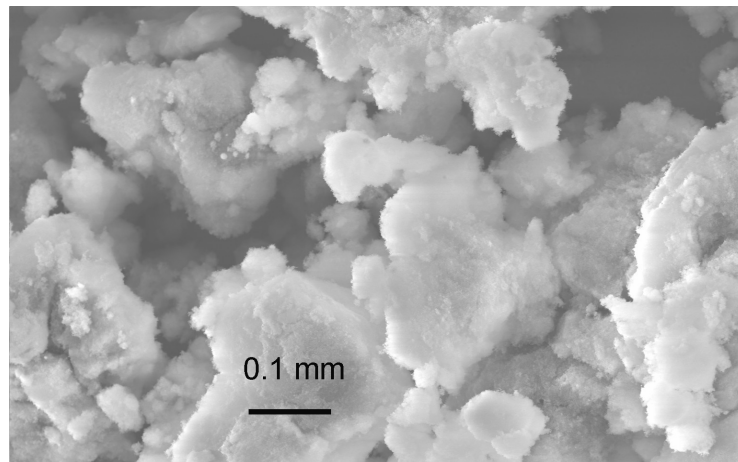

Figure 3. Scanning electron image of the synthesized composite $(\text{TiO}_2)_x(\text{SiO}_2)_{1-x}$.

Presented in figure 4 is a TEM image of the powder and a bar chart of grain-size distribution. Note that the mean size of the composite powder particles is smaller compared to that of pure nanosized titanium dioxide synthesized under similar experimental conditions [3, 4]. This might be attributed to a change in the conditions of coagulation of the particles formed upon addition of a new material.

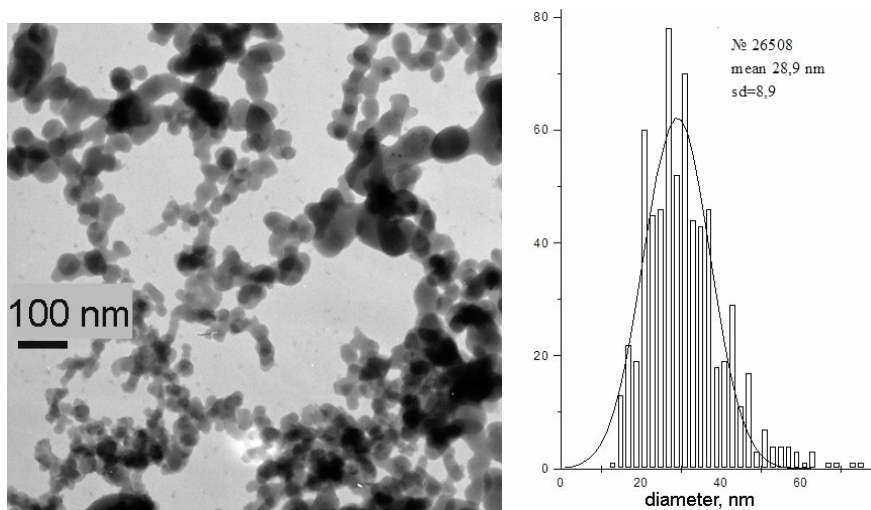

Figure 4. TEM image and a bar chart of grain-size distribution from $(\text{TiO}_2)_x(\text{SiO}_2)_{1-x}$ powder. The mean size is 29 nm. The initial mixture in mmol: $\text{H}_2 + \text{O}_2 + \text{SiCl}_4 + \text{TiCl}_4$ (50 : 25 : 17 : 10).

The resulting composite nanosized oxides may be present as a mixture of individual particles of silicon dioxide and titanium dioxide proper. In order to determine their lattice structure and mixture ratio, the synthesized powder was analyzed in a high-resolution transmission electron microscope. In

addition to TEM images, an analysis was made of the dark-field images of the particles. Brighter images corresponded to the region of coherent scattering. All the particles of the composite oxide under examination exhibited reflections in the diffraction pattern. Smaller particles in the dark-field image were fully bright (figure 5).

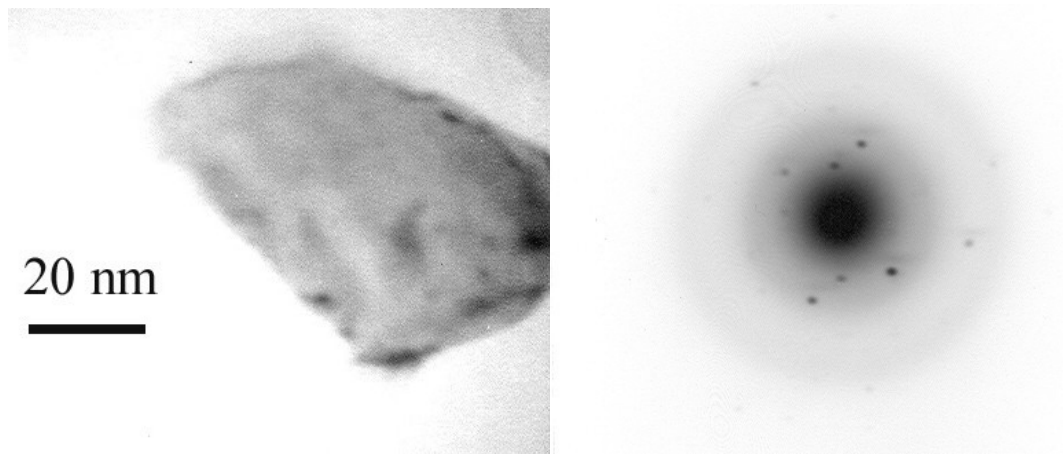

Figure 5. Dark-field TEM-image of a small composite powder particle and its diffraction pattern.

Large particles had individual regions of coherent scattering in their structure (Fig. 6).

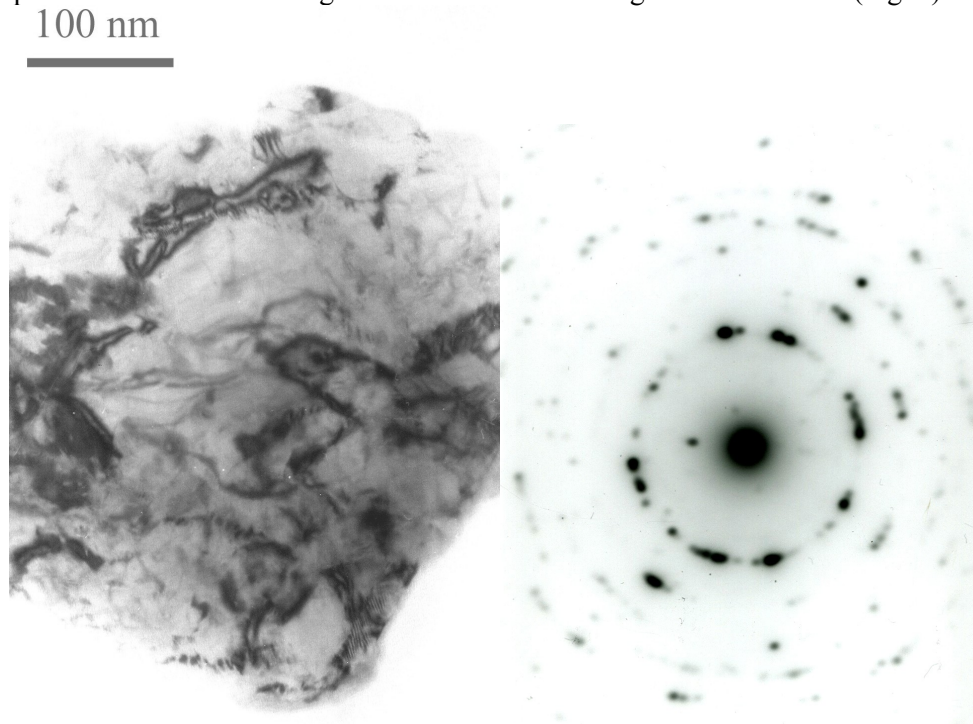

Figure 6. Dark-field TEM-image of a large composite powder particle and its diffraction pattern.

The high-resolution electron microscopy examination of the synthesized composite oxide demonstrated that in our case the mixture of SiO_2 and TiO_2 in one particle are formed.

The chemical composition of the synthesized composite powder was determined in an Oxford ED2000 X-ray fluorescence spectrometer, and the results are listed in Table 1. Taking into account the content of oxygen in the synthesized composite powder, the impurity concentration is less than 0.4 %.

Table 1. Chemical composition of the powder $(\text{TiO}_2)_x(\text{SiO}_2)_{1-x}$

Element	Content, mass %	Element	Content, mass %
Si	55.90±0,08	Mn	0.049±0,01
Ti	43.58±0,01	Cu	0.040±0,01
Fe	0.225±0,01	Zn	0.040±0,01
Cr	0.100±0,01		

The method of plasmachemical synthesis developed here ensures that the chemical composition is maintained for different-size nanoparticles. Presented in Fig. 7 are the images of large (over 100 nm) and small (20...40 nm) particles of $(\text{TiO}_2)_x(\text{SiO}_2)_{1-x}$ and the total EDX-spectrum. The EDX-spectrum was also measured separately for large and small particles of the synthesized powder. The area of the respective peaks is given in Table 2 (in percent).

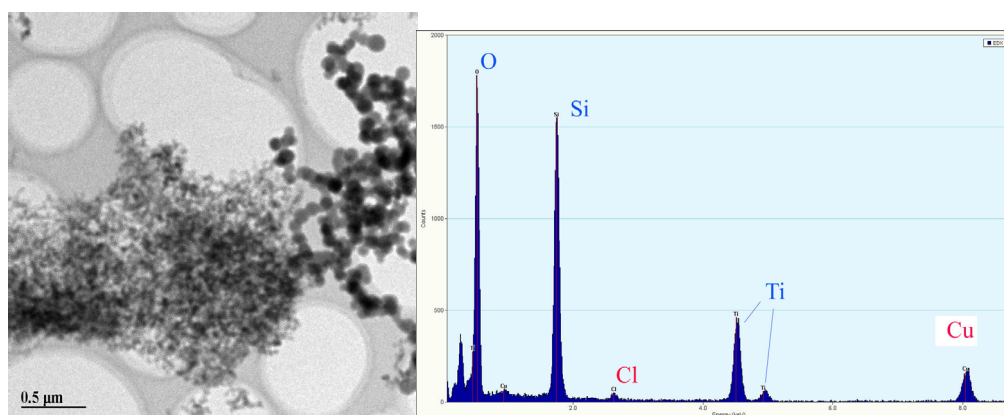

Figure 7. TEM-image and an EDX-spectrum from the $(\text{TiO}_2)_x(\text{SiO}_2)_{1-x}$ powder. Large and small nanoparticles together.

Table 2. Percentage of oxygen, silicon and titanium in the composite powder $(\text{TiO}_2)_x(\text{SiO}_2)_{1-x}$ according to the EDX-spectra

Element	Full spectrum, %	Large particles, %	Small particles, %
O	43	41.4	44.7
Si	37.5	39.1	43
Ti	19.4	19.5	12.2

An X-ray diffraction analysis of the synthesized composite nanosized powder demonstrated that both titanium dioxide proper and composite nanopowder $(\text{TiO}_2)_x(\text{SiO}_2)_{1-x}$ have crystal structure. It is well described by a composition of two types of lattices characteristic of titanium dioxide proper (rutile or anatase). Figure 8 shows the X-ray diffraction patterns from two specimens of the synthesized oxides (rad. Co, $\lambda = 1.7901 \text{ \AA}$), and table 3 presents the data on the proportion of rutile and anatase phases of $(\text{TiO}_2)_x(\text{SiO}_2)_{1-x}$ for different specimens.

Table 3

Specimen	Regime of synthesis	Rutile	Anatase
1	46 mmol H_2 + 23 mmol O_2 + 25 mmol SiCl_4 + 9 mmol TiCl_4	85%	15%
2	46 mmol H_2 + 23 mmol O_2 + 25 mmol SiCl_4 + 18 mmol TiCl_4	47%	53%

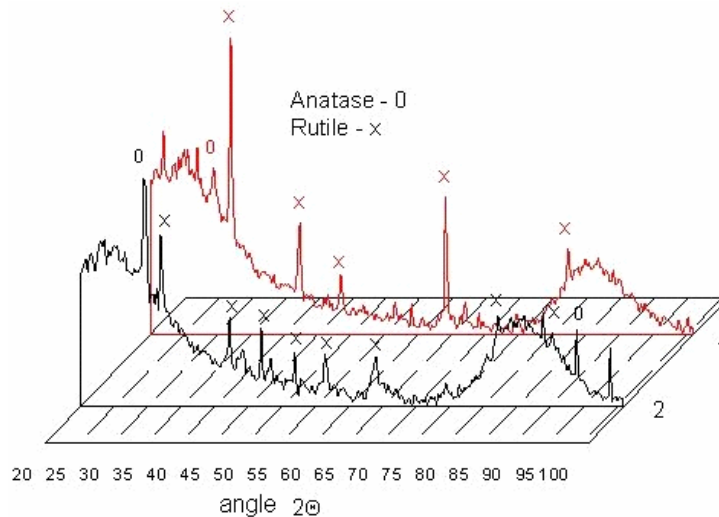

Figure 8. X-ray diffraction pattern from nanosized $(\text{TiO}_2)_x(\text{SiO}_2)_{1-x}$ powder (curves 1 and 2 correspond to table 3).

For comparison, Fig. 9 depicts the X-ray diffraction patterns from silicon dioxide, titanium dioxide, and composite dioxide $(\text{TiO}_2)_x(\text{SiO}_2)_{1-x}$.

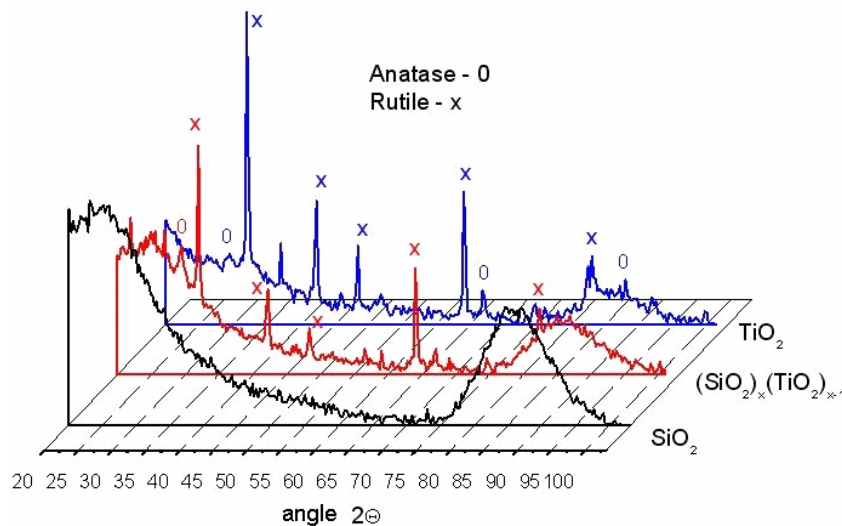

Figure 9. X-ray diffraction patterns from the TiO_2 , SiO_2 and $(\text{TiO}_2)_x(\text{SiO}_2)_{1-x}$ specimens.

All the powders were synthesized by exposing the respective halide with a stoichiometric mixture of oxygen and hydrogen to a pulsed electron beam. A characteristic feature of the composite powder is the presence of a few maximums within the low-angle region ($2\theta = 20-45^\circ$) and in the region from 75 to 90 degrees, which are due to the presence of an amorphous phase of silicon dioxide.

The synthesized nanoparticles were examined in an IR-spectrometer Nicolet 5700 within the range from 400 to 4000 cm^{-1} , the resolution being 4 cm^{-1} . The powder under study was preliminary mixed with KrB and compacted into a tablet. The reflectance spectrum of KrB proper was deducted from that of the mixture. Figure 10 presents a characteristic absorption spectrum from composite $(\text{TiO}_2)_x(\text{SiO}_2)_{1-x}$ nanopowder. For comparison, shown in the figure are also the IR absorption spectra from composite powder and silicon and titanium oxides proper. The absorption peaks with the wave numbers 1190 , 1080 , and 790 cm^{-1} correspond to tetrahedral structure of silicon dioxide ($\nu_{\text{as}}(\text{SiO}_4)$ LO, $\nu_{\text{as}}(\text{SiO}_4)$ TO and $\nu_s(\text{SiO}_4)$, respectively) [5]. In [11], absorption at 960 cm^{-1} is attributed to the presence of a Ti-O-Si bond. Absorption in this region, however, is observed not only for the composite oxide $(\text{TiO}_2)_x(\text{SiO}_2)_{1-x}$ but also for silicon dioxide proper (Fig. 10). It is, therefore, very likely that absorption

of IR light at 960 cm^{-1} corresponds to vibrational excitation of a Si-O-H bond, whose absorption peak corresponds to this wave number [11].

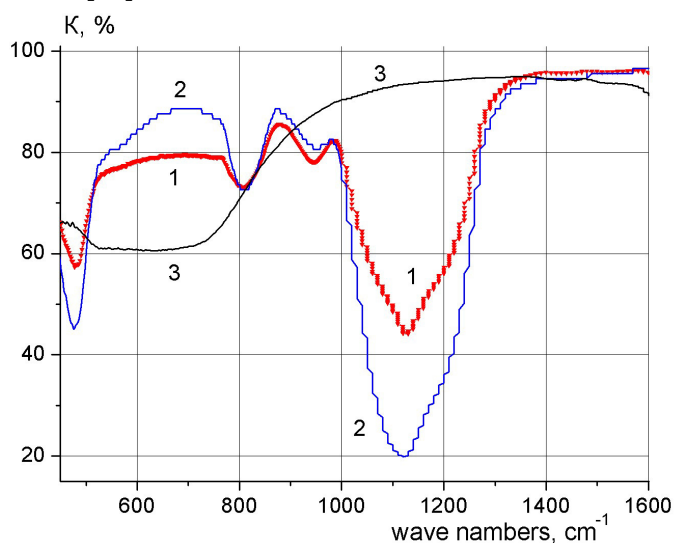

Figure 10. IR spectra from the specimens made of $(\text{TiO}_2)_x(\text{SiO}_2)_{1-x}$ (1), SiO_2 (2), and TiO_2 (3).

The proposed method of synthesizing nanosized titanium dioxide and composite nanosized powder $(\text{TiO}_2)_x(\text{SiO}_2)_{1-x}$ exhibits very high output efficiency (1-1.1 kg/h calculated per final product) and low e-beam energy consumption (0.1-0.15 (kW·h)/kg). The initial bulk density of the nanopowder was (6-10) g/l.

4. Synthesis of composite oxides Si-C-O_x.

One of the large-capacity businesses intensively developing nowadays is the production of technological carbon. The major consumers of carbon – tire manufacturers – need high-quality technological carbon that will ensure higher service safety of vehicles. Moreover, an improved quality of technical carbon also reduces fuel consumption and increases tire service life. Composite nanosized materials containing carbon and silicon dioxide have been recently introduced into tire production, which allows the manufacturers to improve a number of service characteristics of the tires. Currently, there is an evident interest to the research into alternative techniques for carbon production, including plasmocemical methods. Our experimental investigations have demonstrated that a non-equilibrium plasmocemical process initiated by a pulsed electron beam is an effective way to synthesize composite nanosized oxides Si-C-O_x. Shown in Fig. 11 are the TEM-image of the synthesized powder and the bar chart of grain-size distribution.

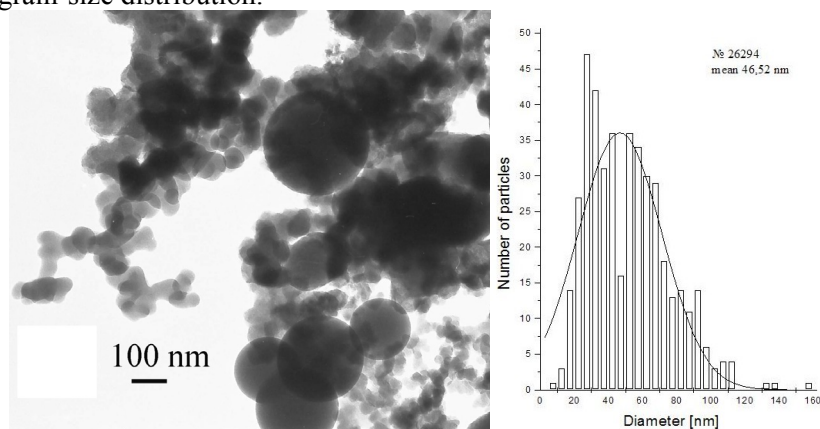

Figure 11. TEM-image and a bar chart of grain-size distribution in Si-C-O_x. Initial mixture: 23 mmol O₂ +46 mmol H₂ + 25 mmol SiCl₄ + 20 mmol CCl₄.

The average grain size of the resulting composite Si-C-O_x powder (46.5 nm) is smaller than that of nanosized silicon dioxide proper [1, 2]. An X-ray diffraction analysis of the synthesized powder reveals that it is amorphous. Figure 12 shows a high-resolution TEM- image of a particle of the synthesized Si-C-O_x powder.

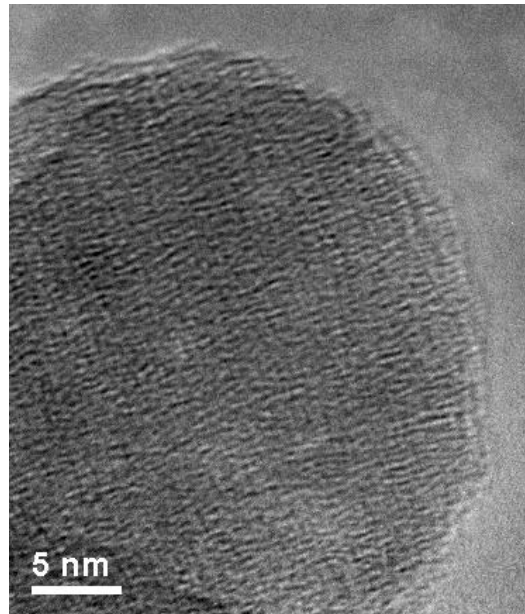

Figure 12. TEM –image of the synthesized nanosized Si-C-O_x powder.

The synthesized nanoparticles were examined in a Nicolet 5700 IR spectrometer within the range from 400 to 4000 cm⁻¹. Figure 13 presents a characteristic absorption spectrum from the nanosized composite Si-C-O_x powder.

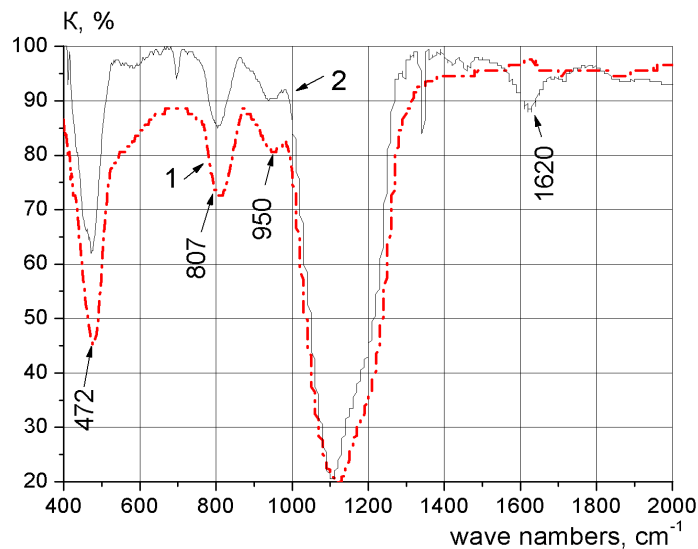

Figure 13. IR-spectrum from silicon dioxide proper (1) and composite Si-C-O_x oxide (2).

Summary.

The experimental research carried out in this work has demonstrated that a plasmochemical process initiated by a pulsed electron beam is an effective way to synthesize nanosized composite oxides from a gas-phase mixture of oxygen, hydrogen, and a mixture of halides. The resulting

nanooxides exhibit homogeneous composition and their particles are spherical in shape with faceting and without voids. A change in the composition of the initial mixture allows one to vary crystal structure, shape and size of the synthesized particles. An outstanding feature of the proposed method is a considerable reduction in temperature for the synthesis of particles with crystalline structure (rutile and anatase), which is due to the non-equilibrium character of the process.

References

- [1]. Remnev G. E., Pushkarev A. I. (2004) Research of chain plasmochemical synthesis of superdispersed silicon dioxide by pulse electron beam. // IEEJ Transactions on fundamentals and materials, vol. 124, №6, p. 483-486.
- [2]. Remnev G. E. and Pushkarev A. I. (2004) Synthesis of nanosized silicon dioxide in a chain plasma-chemical process // High Energy Chemistry, Vol. 38, No. 5, p. 348-350.
- [3]. Remnev G. E., Pushkarev A. I., Ponomarev D. V. (2004) Synthesis of composition nano-dispersed oxides in nonequilibrium plasmochemical process initiated by pulsed electron beam // Proceeding of the 2th European Pulsed Power Symposium EPPS-2004 Hamburg, Germany, p. 28-31.
- [4]. Remnev G. E., Pushkarev A. I., Ponomarev D. V. (2004) The investigation of morphology and phase composition of nanodispersed oxides TiO_2 and Ti-Si-O_x obtained by non-equilibrium plasmochemical synthesis method with the application of pulsed electron beam // 5th International Symposium on Pulsed Power and Plasma Applications, Korea, p.276-280.
- [5]. Wallidge G. W., Anderson R., Mountjoy G., Pickup D. M., Gunawidjaja P., Newport R. J., Smith M. E. (2004) Advanced physical characterization of the structural evolution of amorphous $(\text{TiO}_2)_x(\text{SiO}_2)_{1-x}$ sol-gel materials // Journal of materials science, V. 39, p. 6743 – 6755.
- [6]. Ingo G. M., Riccucci C., Bultrini G., Dire S. and Chiozzini G. (2001) Thermal and microchemical characterization of sol-gel SiO_2 , TiO_2 and $_x\text{SiO}_2\text{-}_{(1-x)}\text{TiO}_2$ ceramic materials // Journal of Thermal Analysis and Calorimetry, Vol. 66, p. 37-46.
- [7]. Machida M., Norimoto K., Watanabe T., Hashimoto K., Fujishima A. (1999) The effect of SiO_2 addition in super-hydrophilic property of TiO_2 photocatalyst // Journal of materials science 3V. 4, p. 2569 – 2574.
- [8]. Young-Geun Kwon, Se-Young Choi, Eul-Son Kang, Seung-Su Baek (2000) Ambient-dried silica aerogel doped with TiO_2 powder for thermal insulation // Journal of Materials Science V.35, № 24, p. 6075-6079.
- [9]. Takahiro G., Takayuki K., Yoshimoto A. (1998) Crystallization Behavior of $\text{SiO}_2\text{-TiO}_2$ ceramics derived from titanosiloxanes on pyrolysis // Journal of Sol-Gel Science and Technology V. 13, №1-3, p. 975-979.
- [10]. Remnev G. E., Furman E. G., Pushkarev A. I., Karpuzov S. B., Kondrat'ev N. A., and Goncharov D. V. (2004) A high-current pulsed accelerator with a matching transformer // Instruments and Experimental Techniques, V. 47, №3, P. 394-398.
- [11]. Ahn W.S., Kang K.K., Kim K.Y. (2001) Synthesis of TS-1 by microwave heating of template-impregnated $\text{SiO}_2\text{-TiO}_2$ xerogels // Catalysis Letters, V. 72, № 3-4. p. 229-232.